



# Low Profile Ball Vise

For Engraving and Jewelry Making

INSTRUCTIONS • #003-615

The GRS Low Profile Ball Vise will provide many years of trouble-free service. It is extremely rugged in construction, yet is relatively simple and easy to maintain. Required lubrication is minimal.

The jaw adapter plates are drilled to accept engraving block attachments. GRS offers an attachment set (#003-520) that includes storage for the adapter plates and pins that come with the block.

## Maintenance

Based on usage, open jaws fully and clean the dirt and metal pieces from the threads. After cleaning, apply a small amount of light oil to the threads. To disassemble, remove the ball swivel tension screw and Spring from the side of the ball. Grasp the crown assembly and carefully lift the crown.

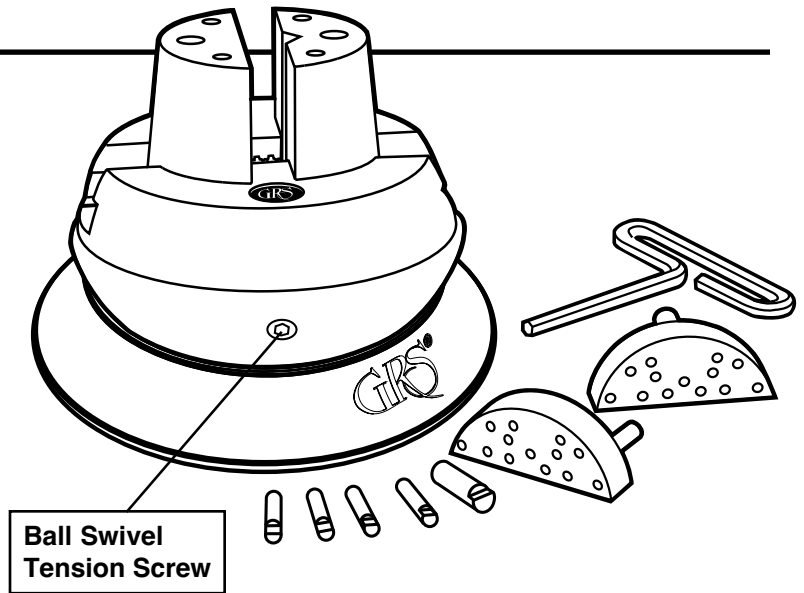

## Vise Jaw Thread Replacement • #003-627 & #003-628

Overtightening the jaws will cause wear and damage to the threads. If jaws become loose, replace with kit #003-627. Remove the jaws by opening them as wide as possible until they come off the end of the jaw screw (**FIG. 1**). The jaw thread pin is located on the underside of each jaw. **NOTE:** Before removing pins, locate the one with the “L”. This is the left hand thread pin and will need to be replaced with the same. Apply a small amount of synthetic grease (included in kit) to the O-rings and jaw screw before installing them. Lift the jaw screw out of the yoke and replace it. Note which side the left hand thread is on. Grease the threads and yoke well.

Start the jaw threads at the same time when replacing them (**FIG. 2**). Hold each jaw in position and turn the jaw screw to close them. Either a large rubber band or a second person is useful to hold the jaws against the thread while the jaw screw is turned. If the jaws don't meet at the same time in the center, remove them and try starting the threads at the same time again.

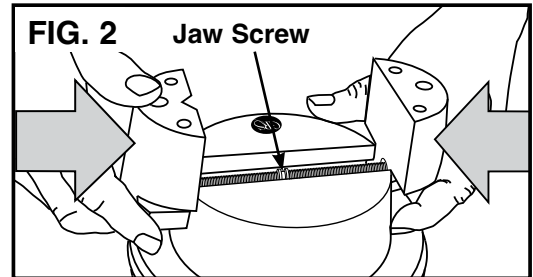
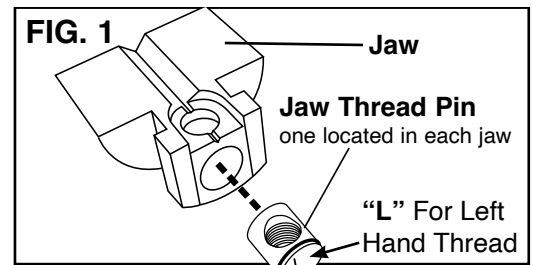

## Rotational Lock Replacement

The LOCK or DRAG PIN is subject to wear and may need replacement after extended use. Simply remove the ball swivel tension screw with the hex wrench. The Spring and Lock Pin should follow (**FIG. 3**). If not, turn the ball until they fall out. Replace the Lock Pin (#003-046), Spring, and Tension Screw.

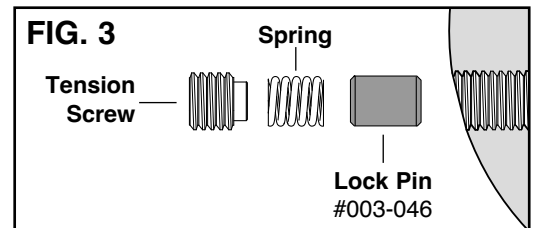

## Turntable Base For Microscope Work • #003-616-V2

To use the Turntable Base, lock the vise by tightening the swivel tension screw until the ball will not turn. The turntable now becomes the means of rotation, allowing the work to be centered in the field of view of the microscope. Align the center of the turntable with the center of the microscope view (**FIG. 4**). Change working views by repositioning the vise.

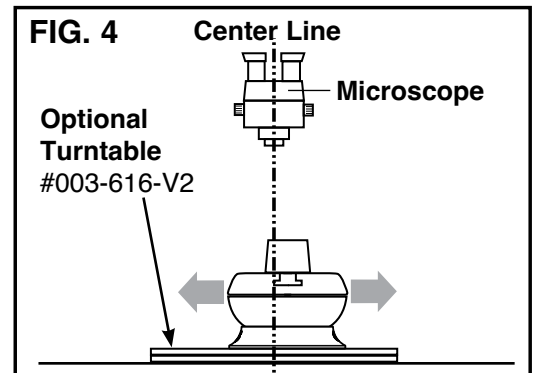

## Thread Pin Replacement Kit • #003-627

Includes Jaw Screw, Left and Right Thread Pins, O-Rings, and Tube of Synthetic Grease.



# Low Profile Ball Vice

For Engraving and Jewelry Making

PARTS LIST • #003-615

## GRS Low Profile Ball Vice Complete Assembly #003-615

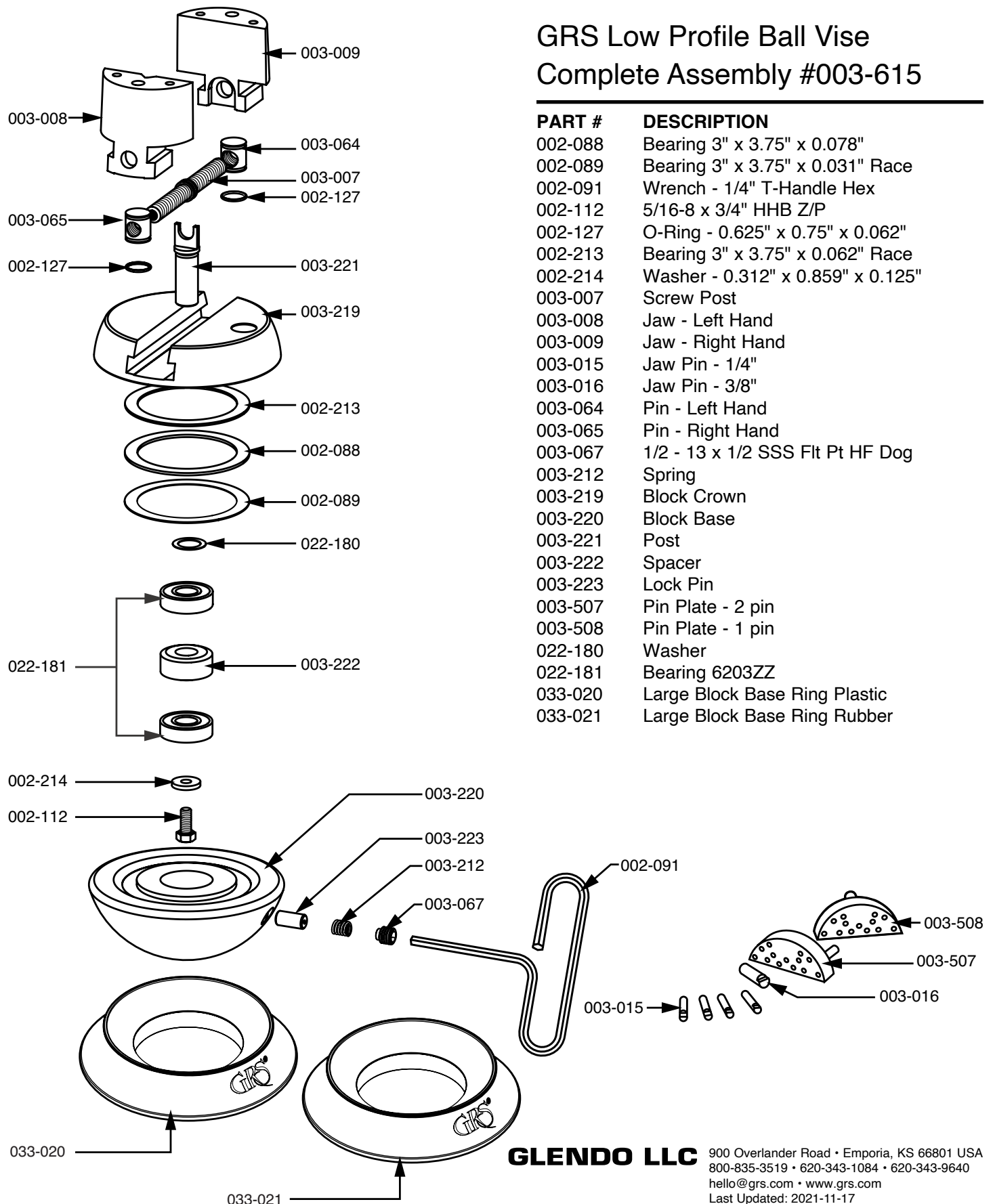

PART #	DESCRIPTION
002-088	Bearing 3" x 3.75" x 0.078"
002-089	Bearing 3" x 3.75" x 0.031" Race
002-091	Wrench - 1/4" T-Handle Hex
002-112	5/16-8 x 3/4" HHB Z/P
002-127	O-Ring - 0.625" x 0.75" x 0.062"
002-213	Bearing 3" x 3.75" x 0.062" Race
002-214	Washer - 0.312" x 0.859" x 0.125"
003-007	Screw Post
003-008	Jaw - Left Hand
003-009	Jaw - Right Hand
003-015	Jaw Pin - 1/4"
003-016	Jaw Pin - 3/8"
003-064	Pin - Left Hand
003-065	Pin - Right Hand
003-067	1/2 - 13 x 1/2 SSS Flt Pt HF Dog
003-212	Spring
003-219	Block Crown
003-220	Block Base
003-221	Post
003-222	Spacer
003-223	Lock Pin
003-507	Pin Plate - 2 pin
003-508	Pin Plate - 1 pin
022-180	Washer
022-181	Bearing 6203ZZ
033-020	Large Block Base Ring Plastic
033-021	Large Block Base Ring Rubber

**GLENDO LLC**

900 Overlander Road • Emporia, KS 66801 USA  
 800-835-3519 • 620-343-1084 • 620-343-9640  
 hello@grs.com • www.grs.com  
 Last Updated: 2021-11-17